

Konvision

www.konvision.com

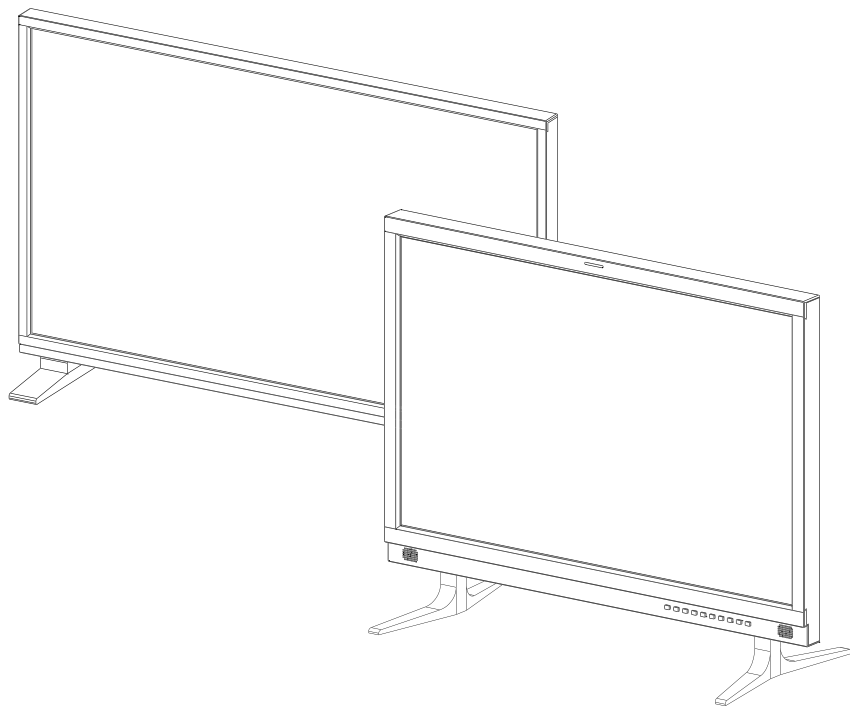

KVM-5X series / KVM-6X series
Konvision32-55inch LCD Monitors Monitor

USER MANUAL

Catalogue

| | | | |
|-------------------------------------|----------|--|-----------|
| Notes | 2 | Histogram..... | 5 |
| Notes..... | 2 | Vector scope..... | 5 |
| Security | 2 | Over exposure..... | 5 |
| Screen Maintenance | 2 | Pixel Measurement..... | 5 |
| Cabinet Maintenance | 2 | Timecode..... | 5 |
| Installation | 3 | Remote Control Function | 5 |
| Rack mount Installation..... | 3 | Parts and Functions | 6 |
| Transportation | 3 | Key Description | 6 |
| The following does not belong to | | Rear View..... | 7 |
| failures:..... | 3 | OSD Menu | 8 |
| Features | 3 | Menu Operation..... | 8 |
| High Brightness LCD Panel..... | 3 | Menu Item Description | 9 |
| High Brightness Tally Indicator ... | 3 | 1. Main Menu:..... | 9 |
| Auto-detection of all color system | | 2. Sub Menu: | 9 |
| (PAL, NTSC)..... | 3 | Status: | 9 |
| 3D Video Decoder | 3 | GPI: | 9 |
| Motion-Adaptive Interlace to | | Picture: | 10 |
| Progressive | 3 | Image: | 10 |
| 10BIT Signal Processing | 4 | Audio: | 11 |
| Support Multiformat SDI Signals | 4 | Marker: | 12 |
| Y/C Input | 4 | Scope: | 13 |
| SDI Input | 4 | Embedded code: (Only for SDI | |
| YPbPr Input..... | 4 | signal)..... | 14 |
| HDMI/DVI/VGA Input..... | 4 | Layout: | 14 |
| Signal Source Loop Through..... | 4 | IMD:..... | 16 |
| PIP/PBP | 4 | Alarm:..... | 17 |
| SWAP Function | 4 | Setup:..... | 17 |
| Color Temperature..... | 4 | Key Lock: | 18 |
| Image Size Setting | 4 | 3. Function Key..... | 18 |
| Marker Setting | 4 | Pixel Measurements Operating | |
| HV Delay | 4 | Instructions | 19 |
| Color Space | 4 | SDI 2K Signal Display Description | 19 |
| Color Calibration..... | 4 | 59 | |
| Scan Mode | 5 | Factory Reset | 19 |
| Part Zoom In..... | 5 | Remote Control | 20 |
| Audio level meter (UV+PPM) | 5 | | |
| Waveform | 5 | | |
| Focus Assist | 5 | | |
| False Color | 5 | | |

Notes

Notes

For the safety use of products, please read the following instructions regarding the installation, use and maintenance carefully.

- Please read the product safety and operating instructions carefully before the product is operated.
- Please keep the safety and operating instructions for future reference.
- Please pay strict attention to the warnings and implement the products according to the operating instructions closely.
- All operating instructions should be strictly enforced.

1. Please use the power cord recommended by the manufacturer.
2. Please do not place heavy objects on the power cord.
3. Please do not expose the monitors to rain, humid, dusty places.
4. Please do not place vessels with liquid (such as cups, beverage bottles) on the monitor.
5. Please do not place this product in high heat places.
6. Please make sure the earth terminal is good in order to avoid electric shock.
7. Please do not open the back cover to avoid electric shock. Please contact professionals for service needs.
8. If there is no image or sound, please unplug the power cord from the AC outlet immediately. Please consult professionals if problem still exists after examining carefully.
9. Do not place this product at unstable places such as cars, shelves or tables, as it is easy to make the product fall down, may cause severe hurt to children and adults and damage to the product.
10. Please do not touch the power plug with wet hands, as it will cause electric shock.
11. Please do not expose the LCD panel in direct sunlight for a long time, it will result in damage or aging of the LCD panel.
12. Please display this product at a suitable temperature and humidity.
13. Please do not spray any liquid things and/or add any objects into the monitor, it might cause voltage instability and short-circuit, also can easily cause fires and blackouts.

14. If do not use the device for a long time, please unplug the power cord from the AC outlet.
15. Please keep not less than 5cm space around the vents while using the monitor, in order to obtain a good heat dissipation effect.

Security

Screen Maintenance

Please follow the below guidelines carefully to prevent discoloration, stains and scratches on the screen:

- Avoid striking the screen with any object.
- Do not wipe the screen hard.
- Do not wipe the screen with solvents such as alcohol, thinner or gasoline.
- Do not spray detergent or other cleaners on the monitor or LCD panel, as it may cause fault because of water droplets into the monitor.
- Do not write on the screen.
- Do not paste or stick any viscous markers on the screen.

Screen may be cleaned by gently wiping with lint free cloth to remove dust. For the more difficult cleaning, use lint free cloth that has been very lightly dampened with detergent, then dry any excess moisture from the monitor or LCD panel immediately to prevent damage.

Cabinet Maintenance

Please follow the guidelines below to prevent potential damage.

- Do not wipe the cabinet with solvents such as alcohol, thinner or gasoline.
- Do not use any pesticides and/or other volatile substances.
- Do not allow prolonged contact with rubber or plastic.
- Do not wipe the cabinet hard. Use a soft, lint free cloth to clean. If the cabinet cleaning is more difficult, use lint free cloth that has been very lightly dampened with detergent and then dry it to wipe.

Installation

- Keep adequate air circulation to prevent device internal overheating. Please do not place the product on the surface of some certain objects (such as blankets, carpets, etc.), as these objects may block the vents.
- Please keep the device away from heat generating sources, such as radiator, heaters and air duct, also keep it away from much dust or mechanical vibration.

Rack mount Installation

For rack mount installation, please keep 1U space from both top and bottom to make sure, adequate air circulation, or install an external electric fan. Please follow the instructions and install with the rack mounts provided by the manufacturer.

Transportation

This monitor is precise equipment and needs professional packing materials to transport. Please do not use packing materials provided by suppliers except KONVISION or its authorized packing material suppliers.

When the following situations occur, please turn off the power, do not insert the plug and contact a professional service staff to deal with it in a timely manner.

1. This product smells of smoke and off-flavor.
2. When this product displays abnormal operating conditions, such as there is no picture or sound.
3. When any liquid is splashed into the product or product dropped.
4. When the product soaked or fell into the water.
5. When the product has been damaged or under other easy to get damaged circumstances.
6. When the power cord or plug is damaged.

The following does not belong to failures:

1. If the static image displayed too long, it will have residual image, which should be attributed to the characteristics of LCD display but not a failure. Residual image will disappear automatically after a period of time.

2. If this device is used in a cold environment, the screen may appear a burn-in image. This is not a product failure, when the monitor temperature changes, screen will return to normal conditions.
3. LCD screen may appear tiny spots (red, blue or green), this is not a fault, LCD screens are manufactured with high precision technology, and a small number of pixels may not be able to show intermittent.
4. Screen and cabinet will become warm gradually during operating.

Features

High Brightness LCD Panel

- High brightness, high contrast, high-speed response and wide viewing angle technology makes the monitor can be used under variety of lighting conditions.

High Brightness Tally Indicator

- The tally function via GPI or LAN port, with two colors red and green.

Auto-detection of all color system (PAL, NTSC)

- This unit detects the color system automatically.

3D Video Decoder

- Process 3D decoding on VIDEO signals, to realize better reduce cross color.

Motion-Adaptive Interlace to Progressive

- It converts interlaced video to progressive video by motion detection, reduce the serrated image.

10BIT Signal Processing

- Signal input, signal processing and image output are 10bit data processing, to ensure the details display of the image.

Support Multiformat SDI Signals

- The SDI interface supports SD-SDI, HD-SDI, dual link HD-SDI and 3G SDI inputs.

Y/C Input

- Decomposition for the luminance signal (Y) and chrominance signals (C) of the video signal can be input through this connector.

SDI Input

- Support multi-format SDI input, SD-SDI, HD-SDI, 3G SDI.
- Support SMPTE425M-A/B 4:4:4 signals.

YPbPr Input

- YPbPr video signal (Compatible YCbCr) can be input through this connector.

HDMI/DVI/VGA Input

- HDMI signal can be input via HDMI to DVI-I converter through DVI connector, DVI signal can be input through DVI connector, VGA signal can be input via VGA to DVI-I converter through DVI connector.

Signal Source Loop Through

- Signal that linked to the input connector will be enlarged and linked to output connector. SDI reclock loop out ensure the signal without enervation.

PIP/PBP

- Two SDI inputs signals display simultaneously under PIP (picture in picture) and PBP (picture by picture) mode. One SDI input signal can be also displayed with another signal of VIDEO, S-VIDEO, COMPONENT, HDMI simultaneously, and showing two pictures on the screen.

SWAP Function

- In PIP/PBP mode, two pictures can be swapped between each other.

Color Temperature

- Different color temperatures can be selected freely.

Image Size Setting

- The display mode is switchable among 16:9, 4:3, full screen, 1:1, and the original image proportion.

Marker Setting

- Show frame borders, center marker, and safety area, etc.

HV Delay

- Display horizontal and vertical blanking area of SDI input signal.

Color Space

- Color space include: Rec 709, EBU, DCI P3 D65, DCI P3, Rec2020, USER. (This function only available to KVM-6X series)

Color Calibration

- This enable to calibrate imported color data of the image being measured by color analyzer. (This function only available to KVM-6X series, specific instructions please contact with the dealer.)

Scan Mode

- Scan mode includes Full Scan, Over Scan, Under Scan. Full scan displays the content of all areas of the input signal. Over scan displays 105% of the area of the input signal. Under scan displays 95% of the area of the input signal.

Part Zoom In

- Zoom in any part of the picture, to watch picture details more clearly, and assist for focus.

Audio level meter (UV+PPM)

- Display the audio level meter (UV+PPM) for SDI embedded audio.

Waveform

- Display input signal waveform and color scope for SDI signal input monitoring. It includes luminance waveform, CbCr waveform. Luminance waveform will mark with red if over the value specified by user.

Focus Assist

- Focus assist is to aid the cameraman focus on the main body by marking the sharpest edge of the image with red.

False Color

- False color can intuitively observe and calculate illumination level in the image, luminance and illumination values display mapping as luminance level, from darkest to brightest, display blue, cyan, green, yellow, orange and red in turn.

Histogram

- YRGB histogram displays the hue distribution of the entire image under SDI input condition, can intuitively display exposure of the image, display R, G, B 3 channels independently.

Vector scope

- Vector UV analysis for color bar signal input.

Over exposure

- Over exposure is to aid the cameraman accurately control the lighting to avoid over exposure by marking the brightness exceeds the user-specified range (95% by default) with the form of covering zebra pattern.

Pixel Measurement

- User can measure any pixel's specific position and RGB value, also can compare the YRGB value between any 2 pixels.

Timecode

- Display SMPTE timecode (LTC, VITC1, VITC2) under SDI input, it is used for identifying and synchronizing of video data streams.

Remote Control Function

- Available to connect to the remote terminal to operate the equipment directly, select the input signal, longitudinal mode settings and tally indicator, etc.

Parts and Functions

Key Description

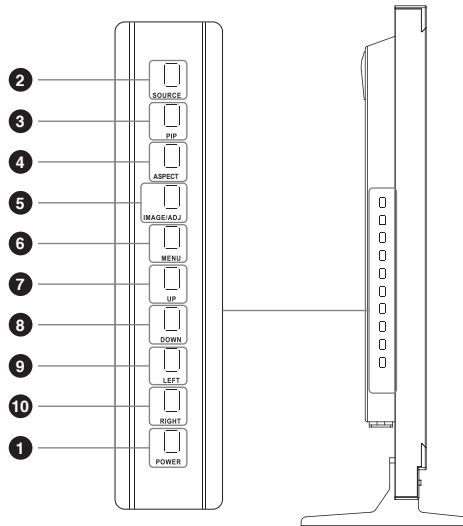

1 Power Button and Indicator

When the external power supply with electricity, the indicator light is red. Press this POWER button to power on the monitor, and the indicator light turns blue. Press this button again turn off the monitor power supply.

2 SOURCE Button

Press this button to select input signal sources. Press this button continuously, the selection input will change accordingly.

SDI1 → SDI2 → VGA → Video → HDMI

SDI1: SDI1 input port of the SDI IN.

SDI2: SDI2 input port of the SDI IN.

VGA: VGA convert to DVI-I input port of the DVI/HDMI/VGA IN.

Video: Video input port.

HDMI: HDMI convert to DVI-I input port of the DVI/HDMI/VGA IN.

3 PIP Button

Press this button to switch between Single window picture mode, Picture in Picture (PIP) mode, and Picture by Picture (PBP) mode. When switch to PIP/PBP mode, one picture must be SDI input, the other picture can be SDI2, HDMI, VGA, Video input.

4 PIP Button

Press this button to select the display ratio of the picture. The picture display ratio will change accordingly.

Original → 16:9 → 4:3 → 1:1 → Full Screen Display

Original: The image display ratio according to original.

16:9: The image display ratio according to 16:9.

4:3: The image display ratio according to 4:3.

1:1: The image display ratio according to 1:1.

Full Screen Display: the image display ratio according to full screen display.

5 IMAGE ADJ Button

Press this button continuously to select between: Backlight, Brightness, Contrast Ratio.

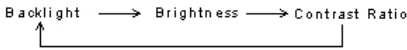

Backlight: When the screen backlight brightness adjustment shortcut menu display, then press LEFT or RIGHT button to adjust the values.

Brightness: When the image brightness adjustment shortcut menu display, then press LEFT or RIGHT button to adjust the values.

Contrast Ratio: When the screen contrast ratio adjustment shortcut menu display, then press LEFT or RIGHT button to adjust the values.

6 MENU Button

Press this button to display the OSD menu, and press it again to quit the menu.
Clear the Marker display.
Clear Display mode.
Turn off the shortcut menu.

7 UP Button

In OSD menu, press this button to move the icon upwards.

8 DOWN Button

In OSD menu, press this button to move the icon downwards.

9 LEFT Button

When in sub-menu, press this button to adjust leftwards the parameter of the selected item.

When not in OSD menu, press this button for shortcut to sound volume adjustment.

When in shortcut function status, press this button to move operation bar leftwards.

10 RIGHT Button

When in OSD main menu, press this button to select different sub-menus rightwards; when in sub-menu, press this button to adjust rightwards the parameter of the selected item.

When not in OSD menu, press this button for shortcut to sound volume adjustment.

When in shortcut function status, press this button to move operation bar rightwards.

Rear View

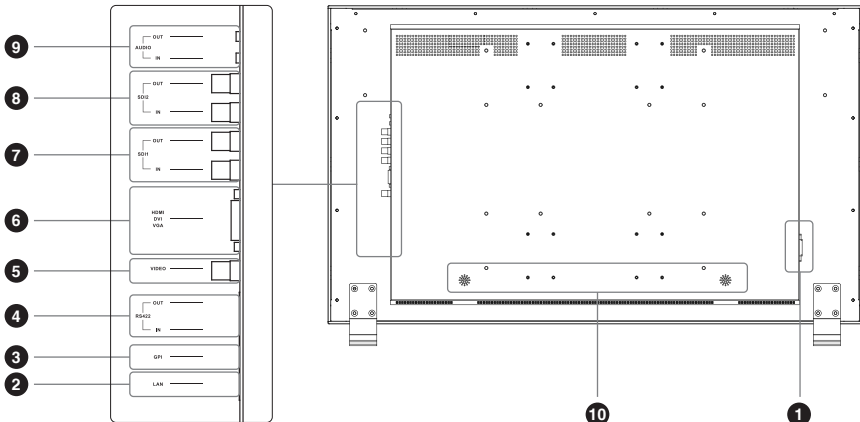

1 AC PORT

AC power supply input.

2 LAN

Ethernet port for remote network control. Thought this port, along with software“Konvision Device Controller”, you can achieve remote controlling to the monitor easily. (remote control software & instructions please contact with the dealer)

3 GPI

GPI interface:

| Diagram | Pin | GPI Signal | Description |
|--|-----|------------|--|
|  | 1 | GPI1 | when connect GND, GPI1 works, GPI1 function can be set in the menu function option. |
| | 2 | GPI2 | when connect GND, GPI2 works, GPI2 function can be set in the menu function option. |
| | 3 | GPI3 | when connect GND, GPI3 works, GPI3 function can be set in the menu function option |
| | 4 | TX | RS232-TX, for MCU program upgrade, please contact the dealer for upgrade operation. When the program is not upgraded, the suspension is not connected. |
| | 5 | RX | RS232-RX, for MCU program upgrade, please contact the dealer for upgrade operation. When the program is not upgraded, the suspension is not connected. |
| | 6 | GPI4 | when connect GND, GPI4 works, GPI4 function can be set in the menu function option |
| | 7 | NC | Not connect |
| | 8 | GND | Ground |

4 RS422 IN and RS422 OUT

RS422 input and output interfaces. RS422 use TSL3.1 or TSL4.0 protocol to control. According to the protocol, it can realize UMD and Tally control.

| Diagram | Pin | RS422 IN Signal name | RS422 OUT Signal name |
|--|-----|----------------------|-----------------------|
|  | 1 | GND | GND |
| | 2 | GND | GND |
| | 3 | Tx- | Tx- |
| | 4 | Rx+ | Rx+ |
| | 5 | Rx- | Rx- |
| | 6 | Tx+ | Tx+ |
| | 7 | NC | NC |
| | 8 | NC | NC |

5 VIDEO

For video signals input.

6 HDMI/DVI/VGA

For HDMI/DVI/VGA signals input. HDMI signal can be input via HDMI to DVI-I converter through DVI connector, DVI signal can be input through DVI connector, VGA signal can be input via VGA to DVI-I converter through DVI connector.

7 SDI1 IN/OUT

SDI1 signal input, monitor the signal input through SDI1 and loop out the signal to other equipment.

8 SDI2 IN/OUT

SDI2 signal input, monitor the signal input through SDI2 and loop out the signal to other equipment.

9 AUDIO(IN/OUT)

Audio in used for analog signal input, Audio out used for monitoring with 3.5mm earphone.

10 Speaker

100-240V AC power supply.

OSD Menu

Menu Operation

1. MENU Button:

Press the Menu button, the main menu will be displayed on the screen, and press the MENU button again to exit the menu.

When in sub-menu, press the MENU button to return to previous menu.

When in setting option, press the MENU button to return to exit.

2. IMAGEADJ(UP/DOWN) Knob:

In the main menu or sub-menu, turn the VOLUME knob to select different items.

3. VOLUME(LEFT/RIGHT) Knob:

In the main menu, turn the VOLUME (right) knob to enter the sub-menu.

In the sub-menu, turn VOLUME (right/left) knob to select the sub-menu item operation.

Menu Item Description

1. Main Menu:

| Main menu | Menu item |
|---------------|-----------|
| Status | 1 |
| GPI | 1 |
| Picture | 1 |
| Image | 1 |
| Audio | 1 |
| Marker | 1 |
| Scope | 1 |
| Embedded code | 1 |
| Layout | 1 |
| IMD | 1 |
| Alarm | 1 |
| Setup | 1 |
| Key Lock | 1 |

2. Sub Menu:

Status:

| Main Menu | Status |
|---------------|--|
| Status | Source&Format SD11 1920x1080I50 |
| Function Key | Fh 28121Hz |
| Picture | Fv 50Hz |
| Image | Color Temp 6500 |
| Audio | Color Space Rec 709 |
| Marker | Image Size FILL ASPECT |
| Scope | Scan Mode 100% Scan |
| Embedded code | Screen Saver YES |
| Layout | Power Saving YES |
| IMD | MCU Firawave Version XSDIM 4 Jun 10 2017 |
| Alara | DSP Firawave Version 7-0-19-2 |
| Setup | |
| Key Lock | |

| Sub Menu | Description |
|-----------------|--|
| Source & Format | Current window input signal and resolution. |
| Fh | The line frequency of the current window input signal. |
| Fv | The field frequency of the current window input signal. |
| Color Temp | The current color temperature. |
| Color Space | The current color space. |
| Image Size | The image size of the current window input signal. |
| Scan Mode | The signal scan mode of the current window input signal. |
| Screen Saver | System screen saver status. |
| Power Saving | System power saving mode status. |

| Sub Menu | Description |
|----------------------|----------------------|
| MCU Firmwave Version | CPU software version |
| DSP Firmwave Version | DSP software version |

GPI:

| Main Menu | Function Key |
|---------------|--------------------|
| Status | GPI1 Blue Mode |
| GPI | GPI2 Red TALLY |
| Picture | GPI3 Green TALLY |
| Image | GPI4 Marker Enable |
| Audio | |
| Marker | |
| Scope | |
| Embedded code | |
| Layout | |
| IMD | |
| Alarm | |
| Setup | |
| Key Lock | |

| Sub Menu | Description |
|----------|--|
| GPI1 | Can be set to the following functions: Blue Mode, Image Size, Marker Display, No Definition, Red TALLY, Green TALLY, SDI1, SDI2, HDMI, DVI, VGA, YPbPr, Video, S-Video |
| GPI2 | Same as above |
| GPI3 | Same as above |
| GPI4 | Same as above |

Picture:

| Main Menu | Picture | |
|---------------|-------------|----------------|
| Status | Backlight | 013 |
| Function Key | Data Levels | Limit (64-940) |
| Picture | Brightness | 050 |
| Image | Contrast | 059 |
| Audio | Sharpness | 007 |
| Marker | Colour | 050 |
| Scope | Hue | 050 |
| Embedded code | Colour Temp | 6500K |
| Layout | | |
| IMD | | |
| Alara | | |
| Setup | | |
| Key Lock | | |

| Sub Menu | Description |
|-------------|---|
| Backlight | Backlight Adjustment. · 0-100 |
| Data Levels | [Limit (64-940)] Select Limit (64-940), video level. [Extend (64-1023)] Select Extend (64-1023), ultra-white. [Full (0-1023)] Select Full (0-1023), full data level. [Custom] Custom is for user definition. · Limit (64-940) · Extend (64-1023) · Full (0-1023) · Custom |
| Brightness | Brightness Adjustment. · 0-100 |
| Contrast | Contrast Adjustment. · 0-100 |
| Sharpness | Sharpness Adjustment. · 0-15 |
| Colour | Saturation Adjustment. · 0-100 |
| Hue | Color Adjustment.. · 0-100 |

| Sub Menu | Description |
|-------------|---|
| Colour Temp | Three modes of the fixed color . temperatures selection (5600K, 6500K, 9300K) and a custom selection. "Custom" is for user definition, to adjust the gain value and offset value of Red, Green and Blue. It will save the color temperature setting automatically. · 5600K · 6500K · 9300K Custom: Red Gain 0-255 Green Gain 0-255 Blue Gain 0-255 Red offset 0-255 Green offset 0-255 Blue offset 0-255 |

Image:

| Main Menu | Image | |
|---------------|------------------------|----------------------------------|
| Status | Image Size | FILL ASPECT |
| Function Key | Scan Mode | 100%Scan |
| Picture | Part Zoom In | <Right>Enter, <Zoom>Part Zoom In |
| Image | Gray Mode | OFF |
| Audio | Blue Mode | OFF |
| Marker | Fast Mode | OFF |
| Scope | H/V Delay | OFF |
| Embedded code | Log Mode | OFF |
| Layout | ColorSpace | Rec 709(Gamma2.4) |
| IMD | Start Color Correction | <Right>to start color Correction |
| Alara | | |
| Setup | | |
| Key Lock | | |

| Sub Menu | Description |
|------------|---|
| Image Size | [FILL ASPECT] Original ratio of the signal source. [Full Screen] Full screen image. [1: 1] At 1:1 pixel-to-pixel display. It is invalid in PIP sub-screen and PBP mode. [16: 9] 16:9 aspect ratio. [4: 3] 4:3 aspect ratio. · FILL ASPECT · Full Screen · 1: 1 · 16: 9 · 4: 3 |
| Scan Mode | [100% Scan] 100% Image display. [Over Scan 5%] 105% Image display. [Under Scan 5%] 95% image display. · 100% Scan · Over Scan 5% · Under Scan 5% |

| Sub Menu | Description |
|--------------|--|
| Part Zoom in | Zoom in any part of the picture, to watch picture details more clearly, and assist for focus. · <Right>Enter, <PIP>Part Zoom in |
| Gray Mode | Monochrome mode with black and white image. · On · Off |
| Blue Mode | Display in Blue only. · On · Off |
| Fast Mode | Interlace scan without converting into progressive scan. · On · Off |
| H/V Delay | Display horizontal & vertical blanking area of SDI input signal. · On · Off |
| Gamma Mode | Users can choose different Gamma or turn it off (this function only available to KVM-6X series) · Turn off · Gamma 2.0 · Gamma 2.2 · Gamma 2.4 · Gamma 2.6 · Rec.2100 HLG 1.0 · Rec.2100 HLG 1.1 · Rec.2100 HLG 1.2 · Rec.2100 HLG 1.3 · Rec.2100 HLG 1.4 · Rec.2100 HLG 1.5 · ST2084 PQ · S-Log3 (HDR) · Slog (SDR) · Slog2 (SDR) · Slog3 (SDR) |

| Sub Menu | Description |
|------------------------|--|
| Color Space | [Bypass] Color Space Choose Bypass. [Rec 709] Color Space Choose Rec709. [EBU] Color Space Choose EBU. [DCI P3 D65] Color Space Choose DCI P3 D65. [DCI P3] Color Space Choose DCI P3. [Rec2020] Color Space Choose Rec2020. [USER1] Color Space Choose User1. [USER2] Color Space Choose User2. · Bypass · Rec 709 · EBU · DCI P3 D65 · DCI P3 · Rec2020 · USER1 · USER2 Remark: 1. KVM-5X series only support Rec709 and Bypass. 2. User1 and user2 option, support user loads their own LUT table, store in there, specific instructions please contactwith the dealer. |
| Start Color Correction | In the menu of Color calibration, press right key to start color calibration, must connect with color analyzer to start color calibration. Notice: restart the monitor to back from color calibration function when misled to the function. · <Right> to start color Correction |

Audio:

| Main Menu | Picture | |
|---------------|-------------|----------------|
| Status | Backlight | 013 |
| Function Key | Data Levels | Limit (64-940) |
| Picture | Brightness | 050 |
| Image | Contrast | 059 |
| Audio | Sharpness | 007 |
| Marker | Colour | 050 |
| Scope | Hue | 050 |
| Embedded code | Colour Temp | 6500K |
| Layout | | |
| IMD | | |
| Alara | | |
| Setup | | |
| Key Lock | | |

| Sub Menu | Description |
|----------|---------------------------------------|
| Volume | Speaker volume adjustment. · 0-100 |

| Sub Menu | Description |
|------------------------|--|
| Headphone Volume | Headphone volume adjustment. · 0-100 |
| Audio Out Mode | [Normal] Right Channel MuteLeft and right channel out normal. [Left Channel Mute] Left channel mute, just out the right channel. [Right Channel Mute] Right channel mute, just out the left channel. · Normal · Left Channel Mute · Right Channel Mute Remark: Only for SDI and HDMI/DVI signal. |
| Audio Out Channel | When in SDI Signal: SDI embedded audio select in CH1&CH2, CH3&CH4, CH5&CH6, CH7&CH8. When in HDMI Signal: HDMI embedded audio selects in CH1&CH2. · CH1&CH2 · CH3&CH4 · CH5&CH6 · CH7&CH8 Remark: Only for SDI and HDMI/DVI signal. |
| Headphone Volume | Turn on/off audio level meter display. · On · Off Remark: Only for SDI and HDMI/DVI signal. |
| Audio Display Channels | When in SDI Signal: 1-4 channels: 1-4 channels are displayed horizontally or vertically on the left side of the screen. 1-8 channels: 1-8 channels are displayed horizontally or vertically on the left side of the screen. 1-16 channels: 1-8 channels are displayed horizontally or vertically on the left side of the screen. 9-16 channels are displayed horizontally or vertically on the left side of the screen. When in HDMI Signal: Only displayed 1-2 channel horizontally or vertically on the left side of the screen.1-4 Channel · 1-8 Channel · 1-16 Channel · 9-16 Channel · 1-2 Channel Remark: Only for SDI and HDMI/DVI signal. |

| Sub Menu | Description |
|---------------------|---|
| Audio Display Mode | [Horizontal] Audio level meter display. [Vertical] horizontal/vertical. · Horizontal · Vertical Remark: Only for SDI/HDMI/DVI signal. |
| Audio Phase Meter | Turn on/off Audio Phase Meter display. · ON · OFF Remark: Only for SDI/HDMI/DVI signal. |
| Audio Phase Channel | When in SDI Signal: SDI Audio Phase Channel can be selected in CH1&CH2, CH3&CH4, CH5&CH6, CH7&CH8. When in HDMI Signal: HDMI Audio Phase Channel only can be selected in CH1&CH2. · CH1&CH2 · CH3&CH4 · CH5&CH6 · CH7&CH8 Remark: only for SDI and HDMI/DVI signal. |
| Audio Phase Channel | Turn on/off audio level meter display. · On · Off Remark: only for SDI and HDMI/DVI signal. |

Marker:

| Main Menu | Marker Setting | |
|---------------|----------------|--------------|
| Status | Marker Enable | OFF |
| Function Key | Marker Select | 4:3 |
| Picture | Target Marker | Center |
| Image | Safety Area | OFF |
| Audio | Marker Level | Middle |
| Marker | Marker Mat | Translucency |
| Scope | | |
| Embedded code | | |
| Layout | | |
| IMD | | |
| Alarm | | |
| Setup | | |
| Key Lock | | |

| Sub Menu | Description |
|---------------|--|
| Marker Enable | [ON] All markers on. [OFF] All markers off. · ON · OFF |
| Marker Select | [OFF] NO marker displays. [4:3] Marker display 4:3. [16:9] Marker display 16:9. [15:9] Marker display 15:9. [14:9] Marker display 14:9. [13:9] Marker display 13:9. [1.85:1] Marker display 1.85:1. [2.35:1] Marker display 2.35:1. · OFF · 4:3 · 16:9 · 15:9 · 14:9 · 13:9 · 1.85:1 · 2.35:1 |
| Target Marker | [ON] Turn on target marker. [OFF] Turn on center mark. [USER] Turn on user target tag. · ON · OFF · USER |
| Safety Area | [OFF] No Safety Area display. [80%] 80% Safety Area display. [85%] 85% Safety Area display. [88%] 88% Safety Area display. [90%] 90% Safety Area display. [93%] 93% Safety Area display. · OFF · 80% · 85% · 88% · 90% · 93% |
| Marker Level | [White] Maker line is white. [Gray] Marker line is gray. [Black] Marker line is black. · White · Gray · Black |
| Target Marker | [OFF] Turn off Fill up the background beyond marker. [Gray] Background beyond marker is gray. [Black] Background beyond marker is black. [Half Transparency] Background beyond marker is half transparent . · OFF · Gray · Black · Half Transparency |

Scope:

| Main Menu | Scope | |
|---------------|----------------|---------|
| Status | Waveform Mode | OFF |
| Function Key | Waveform Alarm | 100% |
| Picture | Waveform Scale | Digital |
| Image | Histogram Mode | OFF |
| Audio | Vector | OFF |
| Marker | Vector Scale | 100% |
| Scope | Zebra | OFF |
| Embedded code | Zebra Level | 95% |
| Layout | Pixel Measure | OFF |
| IMD | False Color | OFF |
| Alarm | focus Assist | OFF |
| Setup | Focus Gain | 25 |
| Key Lock | Focus Color | RED |
| | H Flip | OFF |

| Sub Menu | Description |
|----------------|---|
| Waveform Mode | [OFF] Turn off the waveform mode. [LUMA] Display Y(luminance) waveform. [YUV] Display YCbCr waveform. [FULL LUMA] Display Y (luminance) waveform, one-to-one correspondence between its horizontal coordinates and image horizontal coordinates. · OFF · LUMA · YUV · FULL LUMA |
| Waveform Alarm | Waveform alarm can be set at any percentage between 84%-100%, it will alarm when measured waveform reach or exceed the value you set and mark them with red. · 84%-100% |
| Waveform Scale | [Digital] Display in digital. [IRE] Display in percentage of luminance. · Digital · IRE |
| Histogram Mode | [OFF] Turn off the histogram mode. [LUMA] Display luminance histogram. [RGB] Display R G B histogram. · OFF · LUMA · RGB |
| Vector | Turn on/off vector. · ON · OFF |

| Sub Menu | Description |
|---------------|---|
| Vector Scale | [100%] Vector 100% display. [75%] Vector zoom out to 75% display. · 100% · 75% |
| Zebra | Turn on/off zebra. · ON · OFF |
| Zebra Level | Zebra level can be set at any percentage between 84%-100%, it will alarm when measured luminance reach or exceed the value you set and overlay display with red zebra stripes. · 84%-100% |
| Pixel Measure | Turn on/off pixel measure. · ON · OFF |
| False Color | Turn on/off false color. · ON · OFF |
| Focus Assist | Turn on/off focus assist. · ON · OFF |
| Focus Gain | Focus gainadjustment0-31. · 0-31 |
| Focus Color | [Red] Focus color use Red. [Green] Focus color use Green. [Blue] Focus color use Blue. [White] Focus color use White. · Red · Green · Blue · White |
| H Flip | Turn on/off Horizontal flip. · ON · OFF |

Embedded code: (Only for SDI signal)

| Main Menu | Embedded code | |
|---------------|------------------|-----|
| Status | TimeCode Display | OFF |
| Function Key | TimeCode Mode | LTC |
| Picture | | |
| Image | | |
| Audio | | |
| Marker | | |
| Scope | | |
| Embedded code | | |
| Layout | | |
| IMD | | |
| Alarm | | |
| Setup | | |
| Key Lock | | |

| Sub Menu | Description |
|-------------------|--|
| Time Code Display | Turn on/off Time code. · ON · OFF |
| Time Code Mode | [LTC] Time code display as LTC mode. [VITC1] Time code display as VITC1. [VITC2] Time code display as VITC2. · LTC · VITC1 · VITC2 |

Layout:

| Main Menu | Layout | |
|---------------|-----------------------|--------|
| Status | Layout | Single |
| Function Key | Main Window Source | SDI1 |
| Picture | Current Source Rename | SDI1 |
| Image | | |
| Audio | | |
| Marker | | |
| Scope | | |
| Embedded code | | |
| Layout | | |
| IMD | | |
| Alarm | | |
| Setup | | |
| Key Lock | | |

| Sub Menu | Description |
|----------------------|---|
| Layout | <p>[Single]Display only a single signal picture on screen. [PIP]Display two signals pictures simultaneously on screen, the sub picture in the main picture. [Side by Side]Display two signals pictures side-by-side simultaneously on screen, the sub picture at the right side of the main picture.</p> <ul style="list-style-type: none"> · Single · PIP · Side by Side <p>Remark: In PIP/PBP mode, one of the signals must be SD11, the other signal is any of other input signals. Can display 2 SDI simultaneously.</p> |
| Main Window Source | <p>Main Window select signal input among Video/ S-Video/ YPbPr/ SDI1/SDI2/VGA/ HDMI</p> <ul style="list-style-type: none"> · Video · S-Video · YPbPr · SDI1 · SDI2 · VGA · HDMI · DVI <p>Remark: YPbPr is compatible with RGB, YCbCr, YPbPr.</p> |
| Second Window Source | <p>Second Window select signal input among Video/ S-Video/ YPbPr/ SDI1/SDI2/VGA/ HDMI</p> <ul style="list-style-type: none"> · Video · S-Video · YPbPr · SDI1 · SDI2 · VGA · HDMI · DVI <p>Remark: 1.YPbPr is compatible with RGB, YCbCr, YPbPr. 2.This item shows in PIP/PBP.</p> |
| PIP Size | <p>[Large]The second window is Large size. [Middle]The second window is medium size. [Small]The second window is small size.</p> <ul style="list-style-type: none"> · Large · Middle · Small <p>Remark: 1.This item shows in PIP.</p> |

| Sub Menu | Description |
|--------------|---|
| PIP position | <p>[Left Top]The second window in the left-top corner of screen. [Right Top]The second window in the right-top corner. [Center]The second window in the center. [Right Bottom]The second window in the right-bottom corner. [Left Bottom]The second window in the left-bottom corner. [Custom]The second window is adjusted by user.When the user selects this option, it will automatically pop up at the following "horizontal position" and "vertical position" menu items.</p> <ul style="list-style-type: none"> · Left Top · Right Top · Center · Right Bottom · Left Bottom · Custom |
| H Position | <p>Horizontal position adjustment of picture-in-picture's second window.</p> <ul style="list-style-type: none"> · 0-100 <p>Remark: This item shows when PIP position selects "Custom"</p> |
| V Position | <p>Vertical position adjustment of picture-in-picture's second window.</p> <ul style="list-style-type: none"> · 0-100 <p>Remark: This item shows when PIP position selects "Custom"</p> |
| Alpha Blend | <p>Adjustment of PIP's second window and the main window alpha blend degrees. When the value is 0, the second window is translucent blend with the main window; when the value is 100, the second window blend directly to the main screen.</p> <ul style="list-style-type: none"> · 0-100 |
| Swap | <p>In PIP and PBP, turn right the VOLUME knob to swap the signal pictures between two windows (main window and second window).</p> <ul style="list-style-type: none"> · <Right> to swap two windows <p>Remark: This item shows in PIP/PBP mode.</p> |

| Sub Menu | Description |
|-----------------------|---|
| Current Source Rename | The current signal rename display characters can be arbitrarily set in 8 "xxxxxxx". The setting process: Select the option to the character option, press the VOLUME (LEFT / RIGHT) knob, the option is displayed as "xxxxxxx ok", and the first character becomes red, the user can rotate VOLUME (LEFT / RIGHT) Button to select the desired character. After the first bit is finished, press the VOLUME (LEFT / RIGHT) knob, the second character will be skipped, the second character will be red, and the VOLUME (LEFT / RIGHT) Select the desired character, and so on, the eighth character selection, when the eighth character selection is good, press the VOLUME (LEFT / RIGHT) knob, then "ok" will turn red, rotate VOLUME (LEFT / RIGHT) Knob to "ok" will turn yellow, then press the MENU button to save the exit can be completed UMD main screen character settings. In the setting, only the character "ok" for the yellow state press the MENU button to exit will make the previous character settings saved successfully. If you do not change the "ok" character from red to yellow and press MENU to exit, the previously set characters are not saved. |

IMD:

| Main Menu | IMD | |
|---------------|------------------------|---------------|
| Status | UMD Display | OFF |
| Function Key | UMD ID | 128 |
| Picture | UMD Position | Bottom Center |
| Image | UMD Local Color | GREEN |
| Audio | UMD Main Window Char | UMD-WIN0 |
| Marker | UMD Second Window Char | UMD-WIN1 |
| Scope | UMD PROTOCOL | TSL 3.1 |
| Embedded code | OSD Tally Mode | RG |
| Layout | LED Tally | OFF |
| IMD | LED Tally Source | CPI |
| Alarm | | |
| Setup | | |
| Key Lock | | |

| Sub Menu | Description |
|------------------------|--|
| UMD Display | Turn on/off the UMD display. · ON · OFF |
| UMD ID | UMD ID can be set any value from 128-255. It can be used for multidevice cascading, set different UMD ID for different devices. In remote control situation, this function can be used for distinguishing different devices so as to remote control different devices. · 128-255 |
| UMD Position | [Top Left] UMD display at Top Left. [Top Center] UMD display at Top Center. [Bottom Center] UMD display at Bottom Center. [Bottom Right] UMD display at Bottom Right. · Top Left · Top Center · Bottom Center · Bottom Right |
| UMD Local Color | [GREEN] UMD character display in green. [RED] UMD character display in red. [White] UMD character display in white. · GREEN · RED · White |
| UMD Main Window Char | It can be set any character in "xxxxxxx". Setup process: Select the UMD Main Window item, press VOLUME knob, it shows "xxxxxxx ok", meanwhile, the first character becomes red, user can select the character you need by rotating the VOLUME knob (Left/Right), press the VOLUME knob after finishing first character, it will turn to the second character, select the character you need same as first character, it's also applied to other characters. After finishing selecting the 8th character, press the VOLUME knob, the "ok" will turn red, rotate the VOLUME knob to make the "ok" turn yellow, press MENU to save and exit. Only the "ok" turn yellow, it will save successfully when press MENU, otherwise, it will not save. |
| UMD Second Window Char | Setting is same as UMD Main Window Char. · xxxxxxxx Remark: This item shows in PIP. |

| Sub Menu | Description |
|------------------|---|
| Layout | [TSL3.1] Select TSL3.1. [TSL4.0] Select TSL4.0. [TSL5.0] Select TSL5.0. · TSL3.1 · TSL4.0 · TSL5.0 |
| OSD Tally Mode | [OFF] Turn off OSD Tally. [RG] OSD Tally select RG mode. [GR] OSD Tally select GR mode. [RGY] OSD Tally select RGY mode. · OFF · RG · GR · RGY |
| LED Tally | Turn on/off the LED Tally. · ON · OFF |
| LED Tally Source | [GPI] Select GPI control. [TSL] Select TSL protocol control. · GPI · TSL |

Alarm:

| Main Menu | Alara |
|---------------|----------------------------|
| Status | Alara Display OFF |
| Function Key | No Signal Alara OFF |
| Picture | Black Frame Alara OFF |
| Image | Static Frame Alara OFF |
| Audio | Audio Mute Alara OFF |
| Marker | Audio Level High Alara OFF |
| Scope | Audio Level Low Alara OFF |
| Embedded code | EDH Error Alara OFF |
| Layout | CRC Error Alara OFF |
| IMD | |
| Alara | |
| Setup | |
| Key Lock | |

| Sub Menu | Description |
|-------------------|---|
| Alarm Display | Turn off/on the alarm display. · Off · On |
| No Signal Alarm | Turn off/on the signal alarm. · Off · On |
| Black Frame Alarm | Turn off/on the black frame alarm. · Off · On |

| Sub Menu | Description |
|------------------------|--|
| Static Frame Alarm | Turn off/on the static frame alarm. · Off · On |
| Audio Mute Alarm | Turn off/on the audio mute alarm. · Off · On |
| Audio Level High Alarm | Turn off/on the audio level high alarm. · Off · On |
| Audio Level Low Alarm | Turn off/on the audio level low alarm. · Off · On |
| EDH Error Alarm | Turn off/on the EDH error alarm. · Off · On |
| CRC Error Alarm | Turn off/on the CRC error alarm. · Off · On |

Setup:

| Main Menu | Setup |
|---------------|---------------------------------------|
| Status | Language English |
| Function Key | OSD Settings => |
| Picture | Format Display Auto |
| Image | Power Saving ON |
| Audio | Screen Saver ON |
| Marker | Factory Reset <Right>to Factory Reset |
| Scope | |
| Embedded code | |
| Layout | |
| IMD | |
| Alara | |
| Setup | |
| Key Lock | |

| Sub Menu | Description |
|--------------|--|
| Language | Select Chinese/English in menu. · Chinese · English |
| OSD Settings | [Transparency 0-100] Menu background from opaque to completely transparent selection. [OSD Timeout 1-30] Menu disappear time when no button operation. [H Position 0-100] Menu horizontal position adjust. [V Position 0-100] Menu vertical position adjust. · Transparency 0-100 · OSD Timeout 1-30 · H Position 0-100 · V Position 0-100 |

| Sub Menu | Description |
|----------------|---|
| Format Display | <p>[OFF] Turn off the display info of signal format. [ON] Turn on the display info of signal format. [Auto] Automatically display info of signal format when signal changes, disappear after 4s.</p> <ul style="list-style-type: none"> · OFF · ON · Auto |
| Power Saving | <p>Enter power-saving mode, the system will switch off some functions when the main input is without signal more than 10 minutes. This feature is invalid in PIP/PBP status.</p> <ul style="list-style-type: none"> · ON · OFF |
| Screen Saver | <p>The system will enter screen saver mode when the main input is without signal. This feature is invalid in PIP/PBP status.</p> <ul style="list-style-type: none"> · ON · OFF |
| Factory Reset | <p>Turn right the VOLUME knob, the system restore to factory setting.</p> <ul style="list-style-type: none"> · <Right> to Factory Reset |

Key Lock:

| Main Menu | Key Lock |
|---------------|--------------|
| Status | Key Lock OFF |
| Function Key | |
| Picture | |
| Image | |
| Audio | |
| Marker | |
| Scope | |
| Embedded code | |
| Layout | |
| IMD | |
| Alarm | |
| Setup | |
| Key Lock | |

| Sub Menu | Description |
|----------|---|
| Key Lock | <p>[OFF] Key Lock Off.</p> <p>[ON] When the key lock is turn on, only MENU and VOLUME(LEFT/RIGHT) knob, IMAGEADJ(UP/DOWN) knob can be operate, the rest cannot.</p> <ul style="list-style-type: none"> · OFF · ON |

3. Function Key

| Function Key | | |
|--------------|-------------------|-------------|
| F1 | Image Size | FILL ASPECT |
| F2 | Marker Enable | OFF |
| F3 | Audio Level Meter | OFF |
| F4 | TimeCode Display | OFF |
| F5 | Waveform Mode | OFF |

| Function Key | |
|---------------|-------------------------------------|
| Shortcut Menu | Set up/Description |
| F1 | Press main menu Function key to set |
| F2 | Press main menu Function key to set |
| F3 | Press main menu Function key to set |
| F4 | Press main menu Function key to set |
| F5 | Press main menu Function key to set |

Pixel Measurements

Operating Instructions

Only under SDI/HDMI signal, press this key to perform shortcut key operation: pixel measurement
Pixel Measurement: When you enter the pixel measurement function, press the LEFT button, RIGHT button, UP button, DOWN button, you can measure the large cross of the pixel measurement to move, you can measure any pixel Position and R, G, B values.

Use the pixel measurement function to compare two pixel contrast: When entering the pixel measurement function, press the LEFT button, RIGHT button or UP button, DOWN button to move the big cross to the first pixel. Then press the LEFT and RIGHT button at the same time and the pixel is marked with a small cross mark and then press the LEFT button, RIGHT button or UP button, DOWN button, then the operation will continue to move with a large cross, when the big cross standard to move you to the need to compare another pixel, You can compare the difference between the current pixel and the previous marker pixel.

| | | | | | | | | | |
|---------|------|--------|---|----|----|----|------|------|------|
| Measure | Line | Sample | Y | Y% | Cb | Cr | R256 | G256 | B256 |
| Current | | | | | | | | | |
| Ref_pos | | | | | | | | | |
| Diff | | | | | | | | | |

| Sub Menu | Description |
|----------|--|
| Measure | Measure. |
| Current | Current pixel. |
| Ref-pos | Previous markup pixels. |
| Diff | The difference between the current pixel and the previous pixel. |
| Line | The vertical position of the pixel. |
| Sample | The horizontal position of the pixel. |
| Y | The Y component value of the pixel (range between 0-1023) |
| Y% | The percentage of the Y component of the pixel relative to the maximum, i.e., (Y component value / 256) * 100% |
| Cb | The blue chroma component of the pixel. |
| Cr | The blue chroma component of the pixel. |

| Sub Menu | Description |
|----------|--|
| R | The red component value of the pixel (range between 0-255). |
| G | The green component value of the pixel (range between 0-255) |
| B | The blue component value of the pixel (range between 0-255) |

SDI 2K Signal Display Description

SDI in the 2K signal, the signal beyond the screen display, so look at the part of the image, you need the following operations:

1. Press the SWAP / 1: 1 button, the image is set to 1: 1 display.
2. Rotate the VOLUME (LEFT / RIGHT) knob, you can move the screen left and right, so you can view the screen beyond the screen display.

Factory Reset

This function is to reset the monitor to factory preset. Please try to reset the monitor, when the following situations occur:

1. The monitor parameters are adjusted incorrect by user.
2. The monitor picture or sound is abnormal, and not due to hardware problem.

To do factory reset, please follow the below five steps:

| Main Menu | Setup |
|---------------|---------------------------------------|
| Status | Language English |
| Function Key | OSD Settings => |
| Picture | Format Display Auto |
| Image | Power Saving ON |
| Audio | Screen Saver ON |
| Marker | Factory Reset <Right>to Factory Reset |
| Scope | |
| Embedded code | |
| Layout | |
| IMD | |
| Alarm | |
| Setup | |
| Key Lock | |

1. Press MENU button to enter main menu.
2. Turn VOLUME knob to item Setup and select it.
3. Turn IMAGE ADJ knob to Factory Reset and select it.
4. The screen will refresh after following the instruction of turning the VOLUME knob.
5. Power off the monitor, and must wait for at least 5 seconds, then restart the monitor. The monitor resets to factory preset.

Remote Control

Remote control the monitor through Ethernet:

1. Connected with monitor via LAN, and you can achieve remote controlling by software "Konvision Device Controller". (Network remote control software and instructions please contact with the dealer)
2. The LAN cable should be parallel connection
Parallel line connection: Both ends are 568A standard or both ends are 568B standard.
568A standard: green white, green, orange white, blue, blue white, orange, brown white, brown.
568B standard: orange white, orange, green white, blue, blue white, green, brown white, brown.